



Wide Dynamic Range Transimpedance Amplifier

HIGHLIGHTS

- Wide dynamic range $6\frac{1}{2}$ decades of sensitivity
- Fine gain spacing 16 gain ranges in 1-2-5 spacing
- Small signal rise time (10-90%) 1 μ s
- Noise equivalent current (NEI_{RMS}) 500 pA

APPLICATIONS

- Production automation (eg: connectorization, pigtailing)
- Component testing
- Quality control
- OEM (eg: PER measurements)

MEASUREMENT PRINCIPLE

This TZA400 series of amplifiers employs precision single ended transimpedance input stages to provide for low offset and high linearity throughout the full dynamic range. The single ended input stage is required for applications where the current source is inherently grounded externally.

FIELDS OF APPLICATION

These transimpedance amplifiers are particularly useful for the measurement of current from photodiodes. The output is a voltage linearly proportional to input current and thus, to input power in photodiode monitoring applications. The fast response time at high signal-noise-ratio makes the TZA400 series particularly useful in systems control feedback loops.

These amplifiers have a particularly high sensitivity and large dynamic range. There are 16 gain ranges covering 5 decades of gain in a 1-2-5 pattern. The gain-to-gain accuracy of <1% allows confident measurements of power curves over the full range of sensitivity of the device: $6\frac{1}{2}$ decades of measurement range. Thus even very demanding measurements such as the accurate and high speed, real-time determination of polarization extinction ratio becomes a simple task.

The TZA400 series is insensitive to electromagnetic interference by design, an important factor when working in „dirty“ industrial environments. These units are provided in a modular 19“ rack mount system. Each module comprises a 4 channel amplifier stage allowing the user to conveniently upgrade the channel count of an existing unit.

ABSOLUTE MAXIMUM RATINGS

Average Current	15mA
Temperature Range	0 – 60 °C

ORDERING INFORMATION

Full order code: TZA400 c g S n

	Options	Description	
Case style (c)	G	Gull wing	←
	L	Lab style	
	R	19" Rack module	
Number of gain ranges (g)	4		←
	16		
Number of channels (n)	1 to 4	Gull wing models	←
	1 to 16	Rack mount	

For example, a 2 channel, OEM style unit with fine gain spacing would be ordered as:

TZA400G16S2

For customized systems (mixed receptacles or units with mixed electrical and optical inputs, for example), please contact us.

SPECIFICATIONS

PARAMETER	CONDITIONS	MIN	TYP	MAX	UNITS
INPUT					
Current ranges (full scale)	Maximum range		3.7		mA
	Minimum range		37		nA
Noise equivalent current (NEI _{RMS})	Range: 3.7mA 37nA			2.5 500	µA pA
Connectors		BNC ¹			
OUTPUT		0		3.7	V
Function		Linear analogue $V_{out} = \text{scale} \times I_{in}$			
Connectors		BNC ¹ and DB25			
Output scale with 16 range option	Range: 3.7mA 1.85mA 740µA 370µA 185µA 74µA 37µA 185µA 7.4µA 3.7µA 1.85µA 740nA 370nA 185nA 74nA 37nA		1		V / mA
			2		V / mA
			5		V / mA
			0.01		V / µA
			0.02		V / µA
			0.05		V / µA
			0.1		V / µA
			0.2		V / µA
			0.5		V / µA
			1		V / µA
			2		V / µA
			5		V / µA
			0.01		V / nA
			0.02		V / nA
			0.05		V / nA
			0.1		V / nA
Output scale with 4 range option	Range: 3.7mA 370µA 37µA 3.7µA		1		V / mA
			0.01		V / µA
			0.1		V / µA
			1		V / µA
Output range (full scale)				10	V
Rise / Fall time (10% - 90%)	Source capacitance < 100pF			1	µs
Settling time (1%)	Source capacitance < 100pF			2	µs
Accuracy		± 1			%
Output impedance				50	Ω
LOGIC					
Current required for switching	HI = 5 V LO = 0 V	-100	5 0	100	nA
Dead time during change of range				2 ²	µs
POWER SUPPLY					
Type		Wall plug (supplied)			
DIMENSIONS	1 channel	103 x 45 x 116 mm (w x h x l)			mm
	4 channels	103 x 106 x 116 mm (w x h x l)			mm
	19" rack modules	3U			

¹ Adapters for other connector systems available.

² Limited by settling time. The logical switch is complete within 20ns.

³ 130 mm including case wings

CASE STYLES

(Lab style)

1 CHANNEL

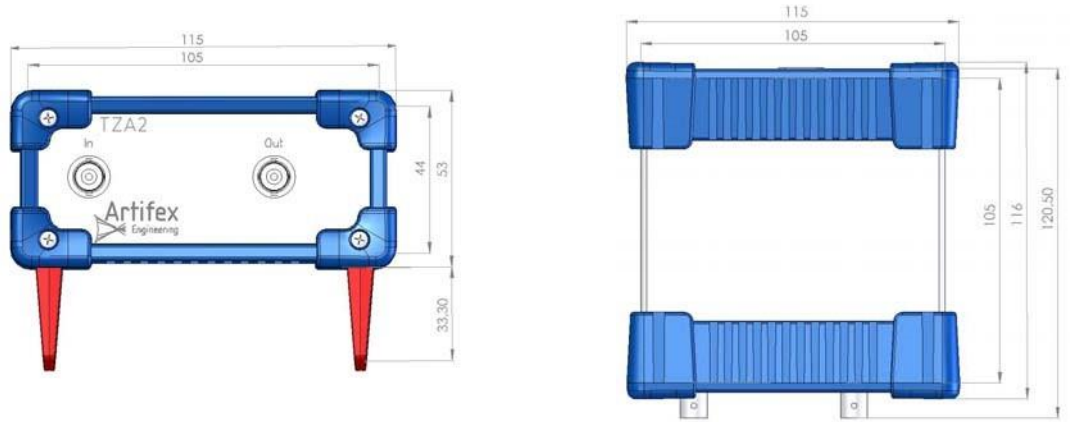

2 CHANNEL

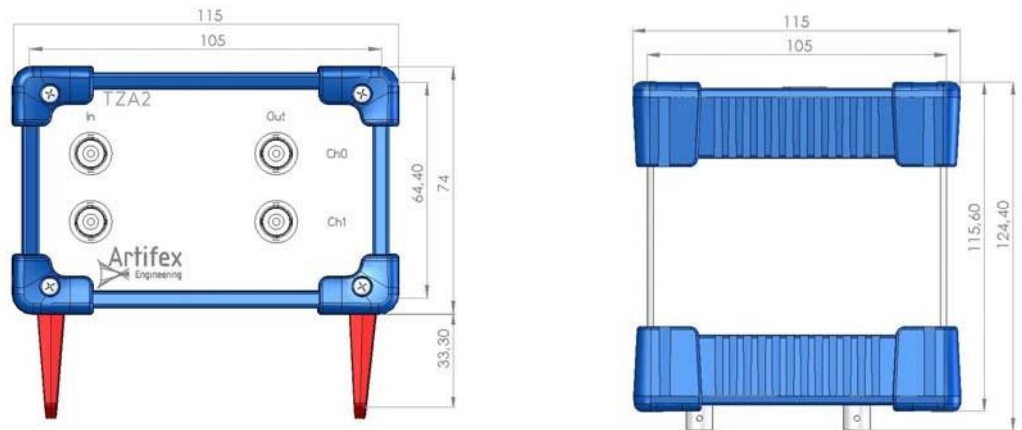

4 CHANNEL

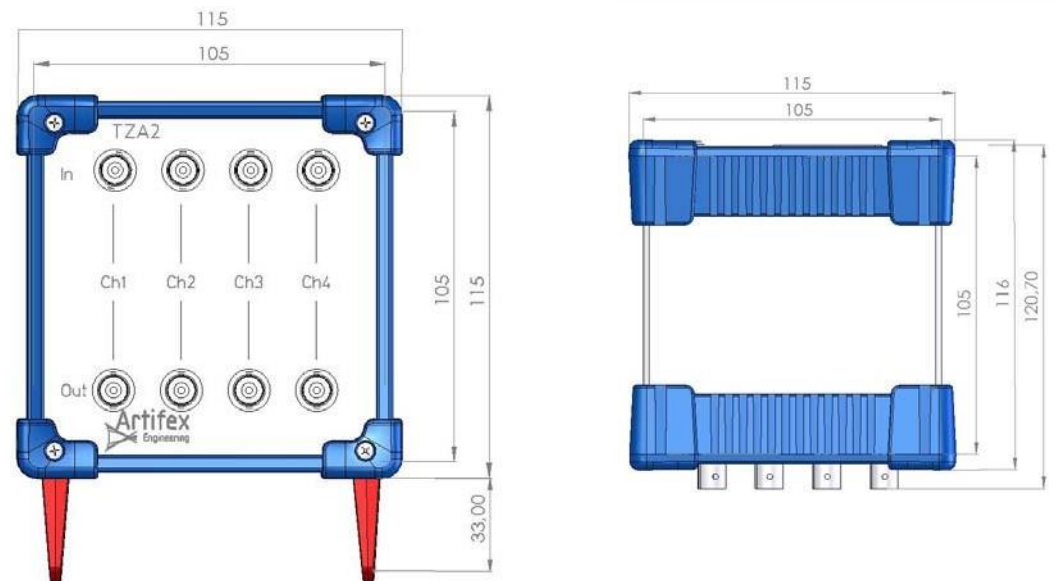

CASE STYLES

(OEM style)

1 CHANNEL

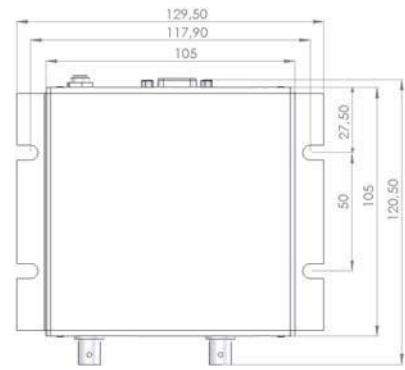

2 CHANNEL

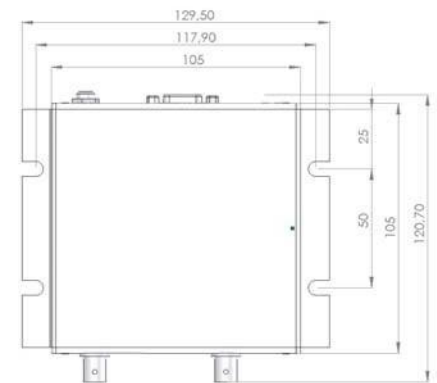
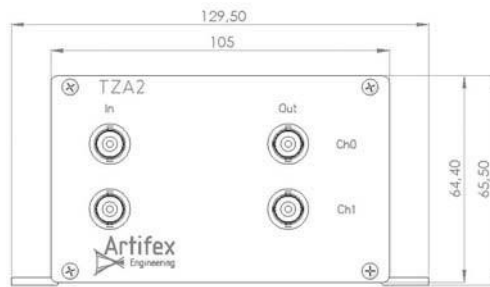

4 CHANNEL

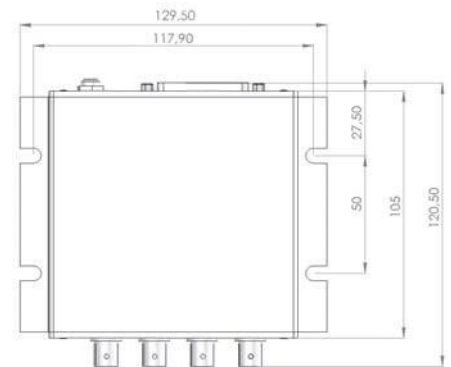
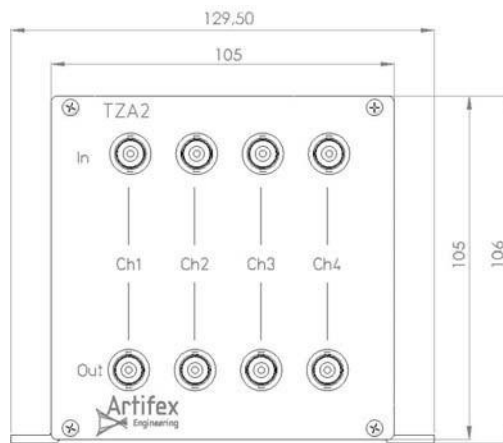

1 TO 16 CHANNELS IN MODULAR 19" RACK SYSTEM

For example, 16 channel unit with power input and interface modules.

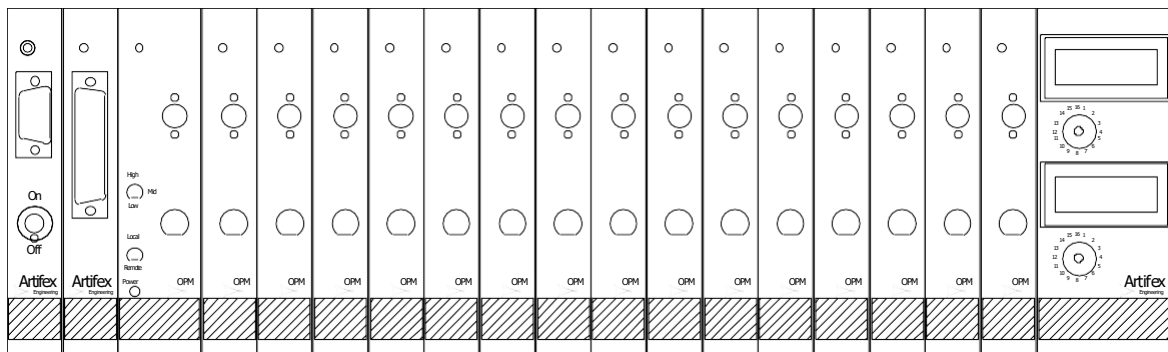

APPLICATIONS EXAMPLES

Typical applications may be found in measuring currents from photodiodes, photomultipliers, ionisation detectors, etc. with applications in component manufacture and testing, OEM, spectroscopy, as preamplifiers for lock-ins, A/D-converters, etc.

LINEAR OR LOGARITHMIC?

The question often arises as to which signal processing technique is better: an output linearly or logarithmically proportional to the input current.

The use of logarithmic amplifiers results from the large dynamic range of relevant currents in many applications. For example, the TZA500 series can measure from 10mA to 100pA: that is, over a range of 8 decades. This dynamic range is far beyond the capabilities of a linear amplifier in a single gain range.

However, by breaking the measurement into range subgroups, linear amplifiers can easily cover the same dynamic range as a logarithmic amplifier. This method is slightly more complicated than using a logarithmic amplifier with a single gain, but it brings several advantages:

1. Linear amplifiers are **more stable** than logarithmic amplifiers
2. Linear amplifiers are **faster** than logarithmic amplifiers and **settle more quickly** following sudden input changes
3. Linear amplifiers are **more accurate** than logarithmic amplifiers at higher outputs

Consider an application example: a TZA is used to measure the current from a photodiode monitoring the power coupled into a device in an automated confectioning system. The device being confectioned may be a laser being pigtailed or fibre being connected to an AWG, for example.

Now the automated positioning system takes the measured value of the coupled power (measured by the photodiode / TZA combination) and uses this value to control the motion stages positioning the fibre. The system searches for the position giving the maximum coupled optical power. Obviously, the accuracy of the positioning will depend on the accuracy of the measurement at the **highest** powers measured. Since the logarithm function compresses data, the position dependence of a logarithmic amplifier is flatter than for the linear amplifier at higher power. Thus, the linear amplifier will allow the system to achieve better results in this application. This point is depicted in the following diagram:

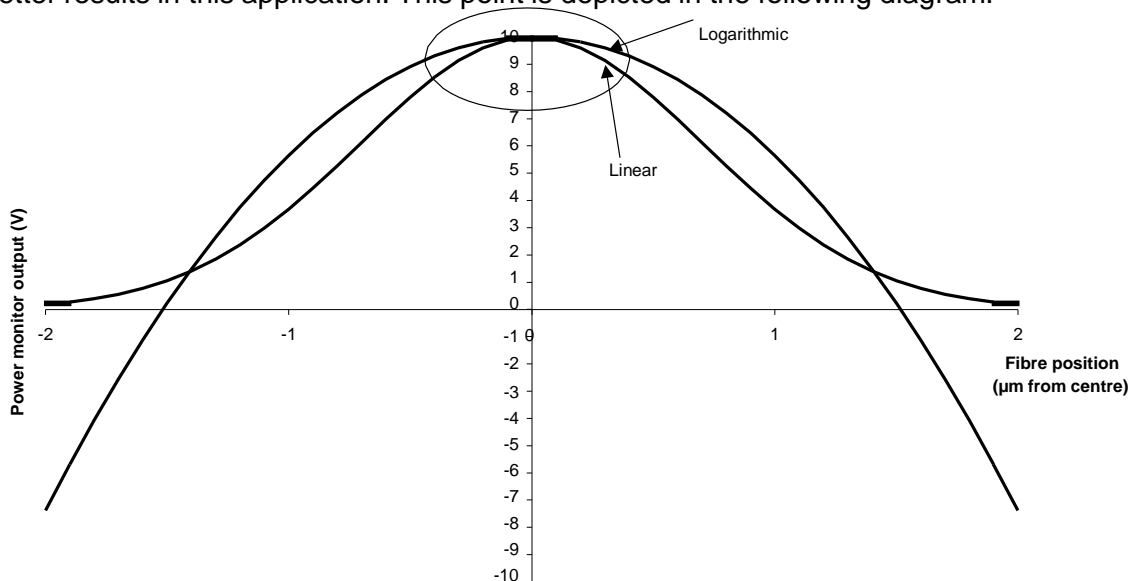

Comparison of linear and logarithmic outputs in a fibre positioning application. The linear output results in a sharper peak allowing more accurate positioning.

THE FRONT AND BACK PANELS

The front panel contains the input and output BNC connectors.

The upper row of BNC connectors is for the current inputs. The channel count begins at the left. If the current source is a photodiode then the cathode is to be connected to the centre pin of the BNC. If a current source other than a photodiode is to be used, then the current drain is to be connected to the centre pin.

The lower row of BNC connectors is for the amplifier outputs. The output is 0-4.5V, linearly proportional to the current input. The channel count begins at the left.

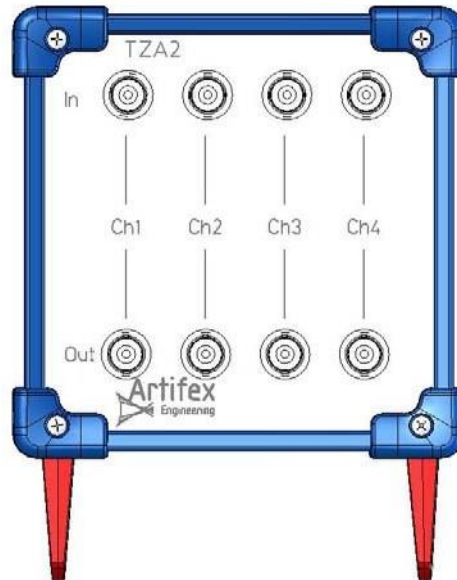

The back panel contains the interface connectors for gain (DB25, male) and for the channel outputs (DB25, female). These outputs are the same as the BNC outputs on the front panel, buffered from another. Thus, the front panel outputs are useful for monitoring (an oscilloscope for example) whereas the back panel outputs are useful for I/O card inputs.

The power input socket is also found here.

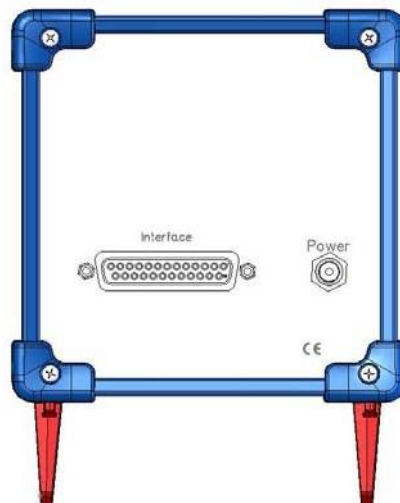

INSTRUCTIONS FOR MEASUREMENT

The TZA400 transimpedance amplifiers comprise one to sixteen independent measurement channels, depending on the model chosen. Each channel consists of a BNC receptacle current input and a BNC-output. These two user interfaces are arranged in logical groups (see „The Front and Back Panels“).

To make a measurement, proceed as follows:

1. Turn the unit on. For the most accurate measurement, please allow for a 15 minute warm up before using.
2. Connect a single ended output current source to the desired channel via the corresponding receptacle.
3. Connect a BNC-cable from the BNC-socket directly underneath the chosen receptacle to a suitable measurement instrument (voltmeter, oscilloscope, I/O card, etc.). Alternatively, the output may be taken from the interface receptacle on the back panel.
4. Select the appropriate range setting for the expected input current (see „Interface“).
5. Turn on the current source to be measured.
6. Read the voltage output and convert to current using the appropriate conversion factor for the range chosen.

CONTROL ELEMENTS

The interfaces on the back panel allows control of the unit, as well as readout of the measurement values.

Interface

This unit is designed for „Remote“ mode gain switching. The range is set via the logic pins of the „Gain“ interface connectors on the back plane. The logic is switched using +5 V / 0 V (= digital ground) logic, which may be TTL⁴. The current drawn is less than 1 μ A. In the following table, „1“ corresponds to 5V logic input and „0“ corresponds to 0V logic input.

Gain [kohm]	I _{max} [A]	Output [V/A]	r = 16 option				r = 4 option		
			Pin 13	Pin 12	Pin 11	Pin 10	Pin 11	Pin 10	
1	3.7mA	1 V/mA	0	0	0	0	→	0	0
2	1.85mA	2 V/mA	0	0	0	1			
5	740 μ A	5 V/mA	0	0	1	0			
10	370 μ A	0.01 V/ μ A	0	0	1	1	→	0	1
20	185 μ A	0.02 V/ μ A	0	1	0	0			
50	74 μ A	0.05 V/ μ A	0	1	0	1			
100	37 μ A	0.1 V/ μ A	0	1	1	0	→	1	0
200	18.5mA	0.2 V/ μ A	0	1	1	1			
500	7.4 μ A	0.5 V/ μ A	1	0	0	0			
1000	3.7 μ A	1 V/ μ A	1	0	0	1	→	1	1
2000	1.85 μ A	2 V/ μ A	1	0	1	0			
5000	740nA	5 V/ μ A	1	0	1	1			
10000	370nA	0.01 V/nA	1	1	0	0			
20000	185nA	0.02 V/nA	1	1	0	1			
50000	74nA	0.05 V/nA	1	1	1	0			
100000	37nA	0.1 V/nA	1	1	1	1			

In the above table, only the pinnings for Channel 1 are indicated. The pinnings for Channels 2 to 4 are analogous (see pinning table on next page).

⁴ LO = TTL low (-0,3 .. +0,8 V); HI = TTL high (+2,4 .. +5,1V)

Please note that this interface does NOT correspond to the RS-232 norm. The interface is designed for direct driving (no protocol) with I/O cards, for example.

The pinning of the output interface (DB25-female) is as follows:

Pin No.	Function
1	AGND (analogue ground)
2	AGND (analogue ground)
3	Ch. 1 output
4	Ch. 2 output
5	Ch. 3 output
6	Ch. 4 output
7	+5V
8	DGND (digital ground)
9	DGND (digital ground)
10	Gain Ch1 (see above)
11	Gain Ch1 (see above)
12	Gain Ch1 (see above)
13	Gain Ch1 (see above)

Pin No.	Function
14	Gain Ch2 (see above)
15	Gain Ch2 (see above)
16	Gain Ch2 (see above)
17	Gain Ch2 (see above)
18	Gain Ch3 (see above)
19	Gain Ch3 (see above)
20	Gain Ch3 (see above)
21	Gain Ch3 (see above)
22	Gain Ch4 (see above)
23	Gain Ch4 (see above)
24	Gain Ch4 (see above)
25	Gain Ch4 (see above)

DAMAGE

The unit may be damaged by exceeding the maximum average input current. Please read „Absolute Maximum Ratings“ for these maximum values before working with the instrument.

Use only the power supply and power supply cable provided with the unit.

TROUBLESHOOTING

In the event that a measurement is not successful, the following possibilities should be analysed:

Symptom	Possible Errors	Correction
No output	<ul style="list-style-type: none">• System is not switched on• Fuse blown⁵	<ul style="list-style-type: none">• Ensure the power cord is connected at both ends and switch the system on.
No output	<ul style="list-style-type: none">• Input power too low• Input or output connection not correct	<ul style="list-style-type: none">• Switch to more sensitive range or increase input power• Ensure that the connectors are inserted correctly and locked. In multichannel units, ensure that the channel being monitored corresponds to the input channel. Ensure that the interface plug is securely seated and the screws fastened.
Output at full scale, independant of input current	Range too sensitive	Switch to a less sensitive range or lower the input current.

In the unlikely event that you are not able to obtain a measurement in spite of these troubleshooting measures, please contact us. We will be pleased to help you solve your problem.

⁵ Secondary, internal self resetting fuses, only. In the event that a secondary fuse „blows“, shut off the power, correct the fault and wait a few minutes before switching the power back on.



NOTICE

Artifex Engineering reserves the right to make changes to its products or to discontinue any product or service without notice and advises customers to obtain the latest version of relevant information to verify, before placing orders, that information being relied on is current and complete. All products are sold subject to the terms and conditions of sale supplied at the time of order acknowledgement, including those pertaining to warranty, patent infringement and limitation of liability.

Customers are responsible for their applications using Artifex Engineering components.

Artifex Engineering assumes no liability for applications assistance or customer product design. Artifex Engineering does not warrant or represent that any license, either express or implied, is granted under any patent right, copyright, or other intellectual property right of Artifex Engineering covering or relating to any combination, machine, or process in which such products or services might be or are used. Artifex Engineering's publication of information regarding any third party's products or services does not constitute Artifex Engineering's approval, warranty or endorsement thereof.

Copyright © 2014, Artifex Engineering

Singapore Main Office
Telephone: +65 6996 0391
Email: info@simtrum.com

China Main Office
Telephone: +86 150 0085 3620
Email: sales@simtrum.cn

www.simtrum.com