

Linear Piezo Stage



2023 V1

For customized projects please Contact us:
info@simtrum.com

Linear Piezo Stage - ST-LS1-0310

Our ST-LS1-0310 is a mini nano linear piezo stage with stroke up to 10mm. It has a maximum load capacity of 0.3kg and has repeatability of +/-500nm.

Feature

- Piezoelectric motor drive, self-locking when power off, saving energy and reducing heat generation
- Simple and compact design
- Grating feedback, optional resolution
- Can be used in optical assembly, micro-nano processing, laser, automation and other fields



Specification

Model	ST-LS1-0310
Stroke(mm)	10
Driver	Piezoelectric Motor
Maximum Load Capacity(KG)	0.3
Maximum Speed(mm/s)	100 (Open Loop)
Minimum Step Size(nm)	300
Repeatability(nm)	+/-500
Material	Aluminum Alloy
Weight(KG)	0.1

Drawings

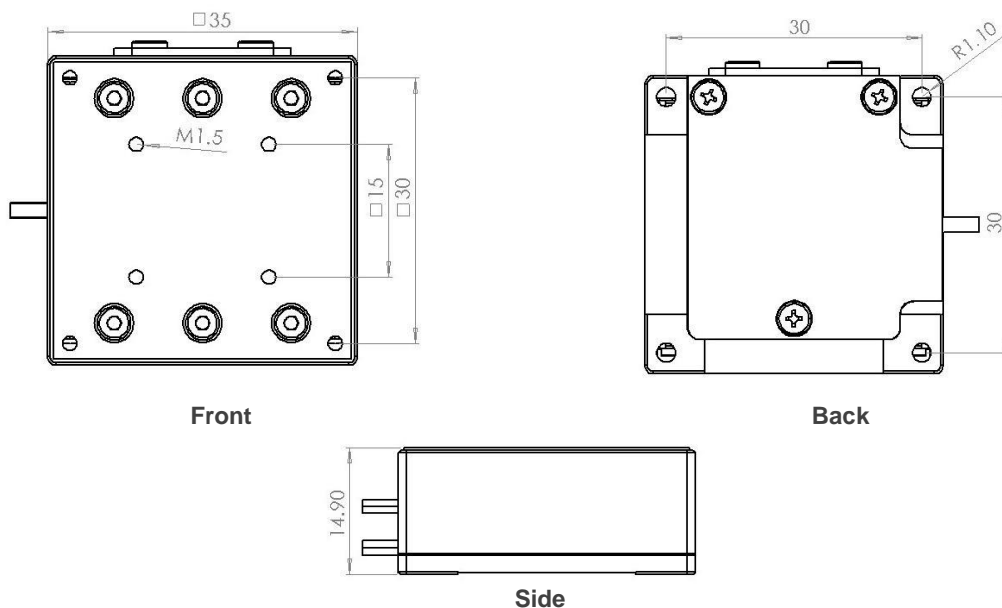

Linear Piezo Stage – ST-LS2-0513S

Our ST-LS2-0513S is a linear piezo stage with stroke up to 13mm. It has a maximum load capacity of 1kg and has repeatability of +/-200nm.

Feature

- Piezoelectric motor drive, self-locking when power off, saving energy and reducing heat generation
- Simple and compact design
- Grating feedback, optional resolution
- Can be used in optical assembly, micro-nano processing, laser, automation and other fields



Specification

Model	ST-LS2-0513S
Stroke(mm)	13
Driver	Piezoelectric Motor
Maximum Load Capacity(KG)	1
Maximum Speed(mm/s)	100
Minimum Step Size(nm)	50(Display Position Feedback)
Repeatability(nm)	+/-200
Position Sensor	Grating
Material	Aluminum Alloy
Weight(KG)	0.18

Drawings

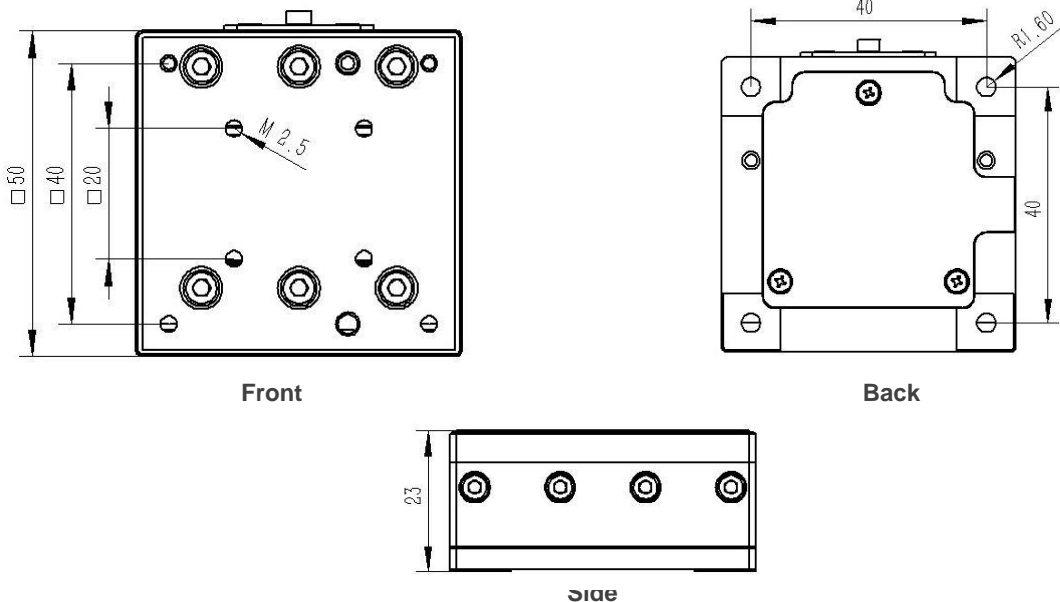

Linear Piezo Stage - ST-LS2-0618S

Our ST-LS2-0618S is a linear piezo stage with stroke up to 18mm. It has a maximum load capacity of 0.5kg and has repeatability of +/-200nm.

Feature

- Piezoelectric motor drive, self-locking when power off, saving energy and reducing heat generation
- Simple and compact design
- Grating feedback, optional resolution
- Can be used in optical assembly, micro-nano processing, laser, automation and other fields



Specification

Model	ST-LS2-0618S
Stroke(mm)	18
Driver	Piezoelectric Motor
Maximum Load Capacity(KG)	0.5
Maximum Speed(mm/s)	100
Minimum Step Size(nm)	50(Display Grating Feedback)
Repeatability(nm)	+/-200
Position Sensor	Grating
Material	Aluminum Alloy
Weight(KG)	0.25

Drawings

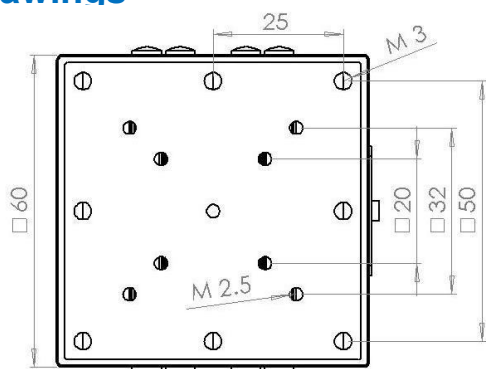

Front

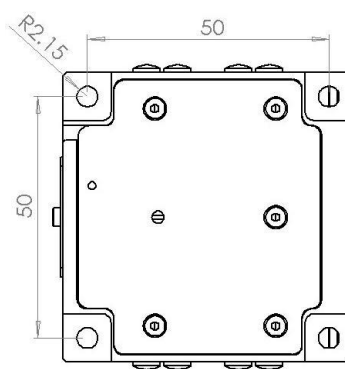

Back

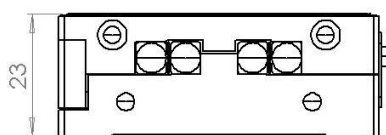

Side

Linear Piezo Stage - ST-LS2-0620R

Our ST-LS2-0620R is a linear piezo stage with stroke up to 20mm. It has a maximum load capacity of 1kg and has repeatability of +/-5mm.

Feature

- Piezoelectric motor drive, self-locking when power off, saving energy and reducing heat generation
- Simple and compact design
- Resistance encoder feedback
- Can be used in optical assembly, micro-nano processing, laser, automation, portable instruments and other fields



Specification

Model	ST-LS2-0620R
Stroke(mm)	20
Driver	Piezoelectric Motor
Maximum Load Capacity(KG)	1
Maximum Speed(mm/s)	100
Minimum Step Size(um)	3
Repeatability(um)	+/-5
Position Sensor	Resistance Encoder
Material	Aluminum Alloy
Weight(KG)	0.55

Drawings

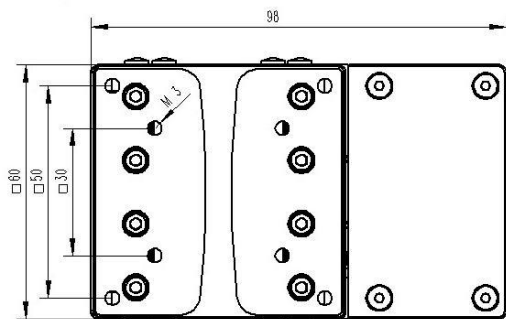

Front

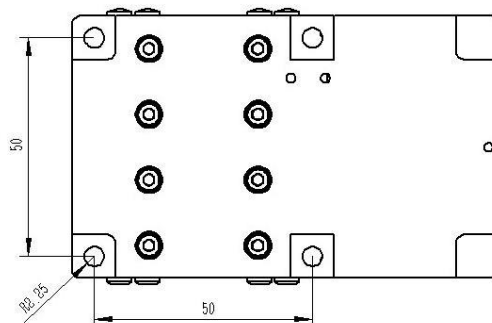

Back

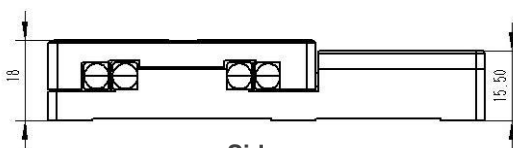

Side

Linear Piezo Stage - ST-LS2-0825S

Our ST-LS2-0825S is a linear piezo stage with stroke up to 25mm. It has a maximum load capacity of 2kg and has repeatability of +/-200nm.

Feature

- Piezoelectric motor drive, self-locking when power off, saving energy and reducing heat generation
- Simple and compact design
- Grating feedback, optional resolution
- Can be used in optical assembly, micro-nano processing, laser, automation and other fields



Specification

Model	ST-LS2-0825S
Stroke(mm)	25
Driver	Piezoelectric Motor
Maximum Load Capacity(KG)	2
Maximum Speed(mm/s)	100
Minimum Step Size(nm)	50(Display Grating Feedback)
Repeatability(nm)	+/-200
Position Sensor	Grating
Material	Aluminum Alloy
Weight(KG)	0.5

Drawings

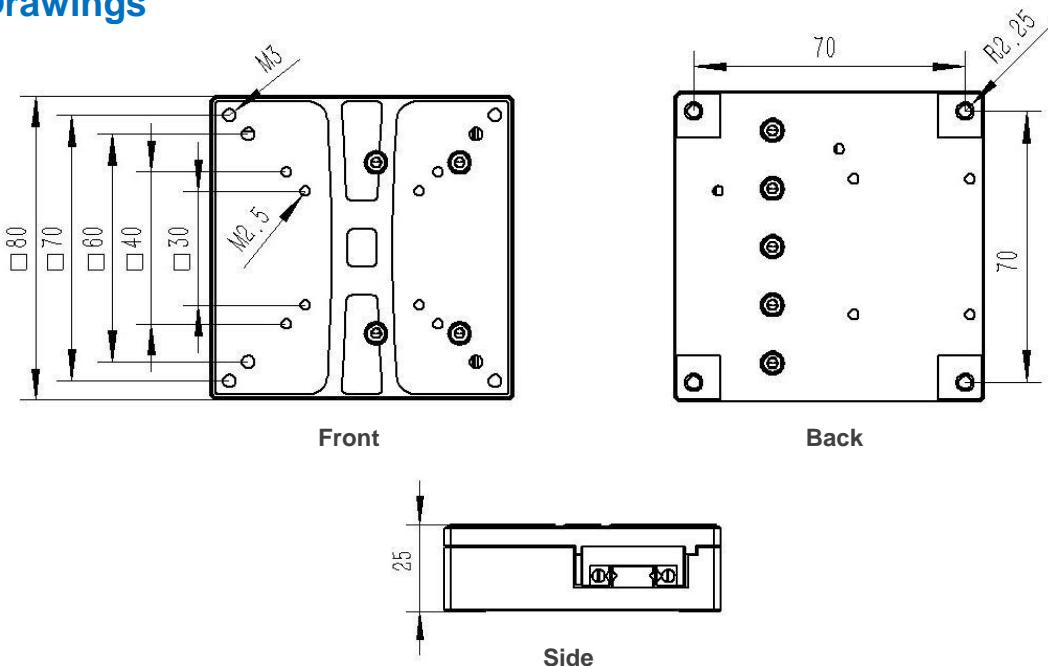

Linear Piezo Stage - ST-LS3-1060

Our ST-LS3-1060 is a linear piezo stage with stroke up to 60mm. It has a maximum load capacity of 5kg and has repeatability of +/-200nm.

Feature

- Piezoelectric motor drive, self-locking when power off, saving energy and reducing heat generation
- Simple and compact design
- Grating feedback, optional resolution
- Can be used in optical assembly, micro-nano processing, laser, automation and other fields



Specification

Model	ST-LS3-1060
Stroke(mm)	60
Driver	Piezoelectric Motor(304)
Maximum Load Capacity(KG)	5
Maximum Speed(mm/s)	100
Minimum Step Size(nm)	20(50, 100nm for Option)
Repeatability(nm)	+/-200
Position Sensor	Grating
Material	Aluminum Alloy

Drawings

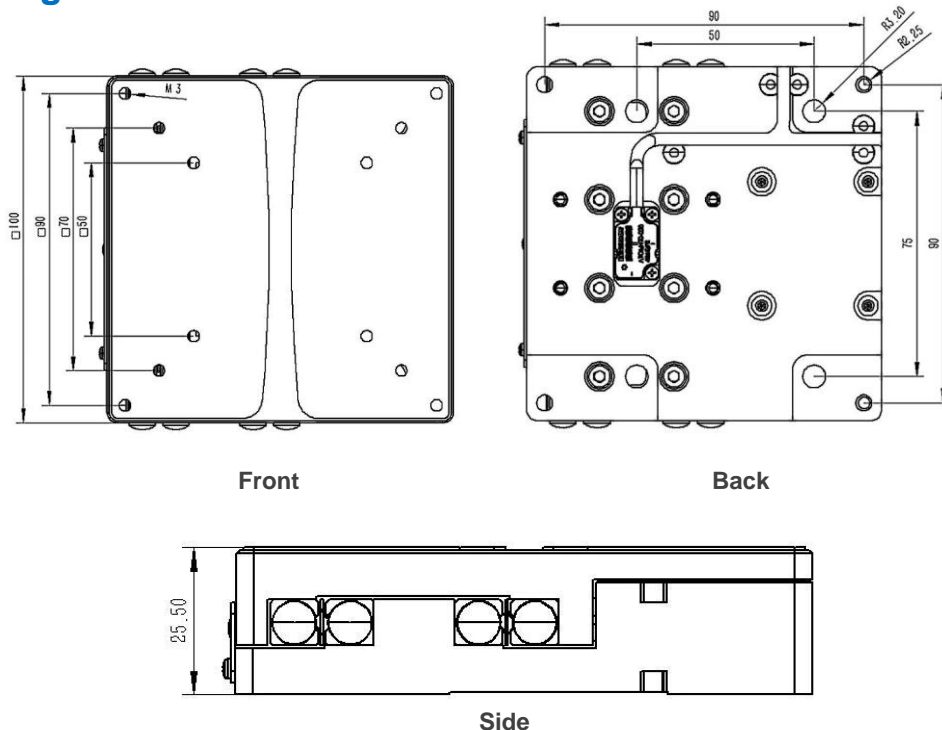

Linear Piezo Stage - ST-LS3-90T

Our ST-LS3-90T is a linear piezo stage with stroke up to 90mm. It has a maximum load capacity of 1.5kg and has repeatability of +/-200mm.

Feature

- Piezoelectric motor drive, self-locking when power off, saving energy and reducing heat generation
- Simple and compact design
- Grating feedback, optional resolution
- Can be used in optical assembly, micro-nano processing, laser, automation and other fields



Specification

Model	ST-LS3-90T
Stroke(mm)	+/-45
Driver	Piezoelectric Motor
Maximum Load Capacity(KG)	2
Maximum Speed(mm/s)	100
Minimum Step Size(nm)	50(Displaying Position Feedback)
Repeatability(nm)	+/-200
Position Sensor	Grating
Material	Aluminum Alloy
Weight(KG)	1.5

Drawings

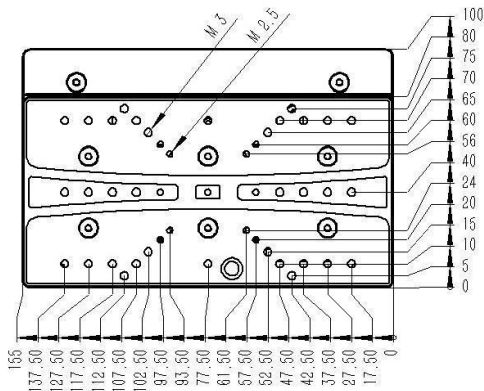

Front

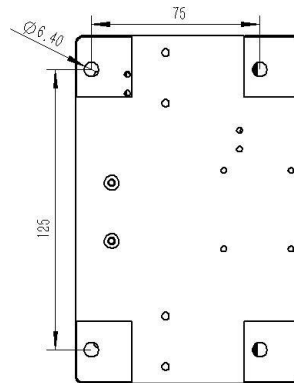

Back

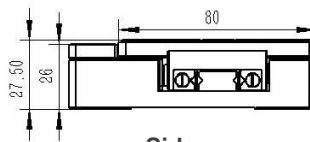

Side

Linear Piezo Stage - ST-LSHK-200

Our ST-LSHK-200 is a linear piezo stage with stroke up to 200mm. It has a maximum load capacity of 10kg and has repeatability of +/-200nm.

Feature

- Piezoelectric motor drive, self-locking when power off, saving energy and reducing heat generation
- Simple and compact design
- Grating feedback, optional resolution
- Can be used in optical assembly, micro-nano processing, laser, automation and other fields



Specification

Model	ST-LSHK-200
Stroke(mm)	200
Driver	M308
Maximum Load Capacity(KG)	10
Maximum Speed(mm/s)	50
Minimum Step Size(nm)	50
Repeatability(nm)	+/-200
Position Sensor	Grating
Material	Aluminum Alloy
Weight(KG)	4.8

Drawings

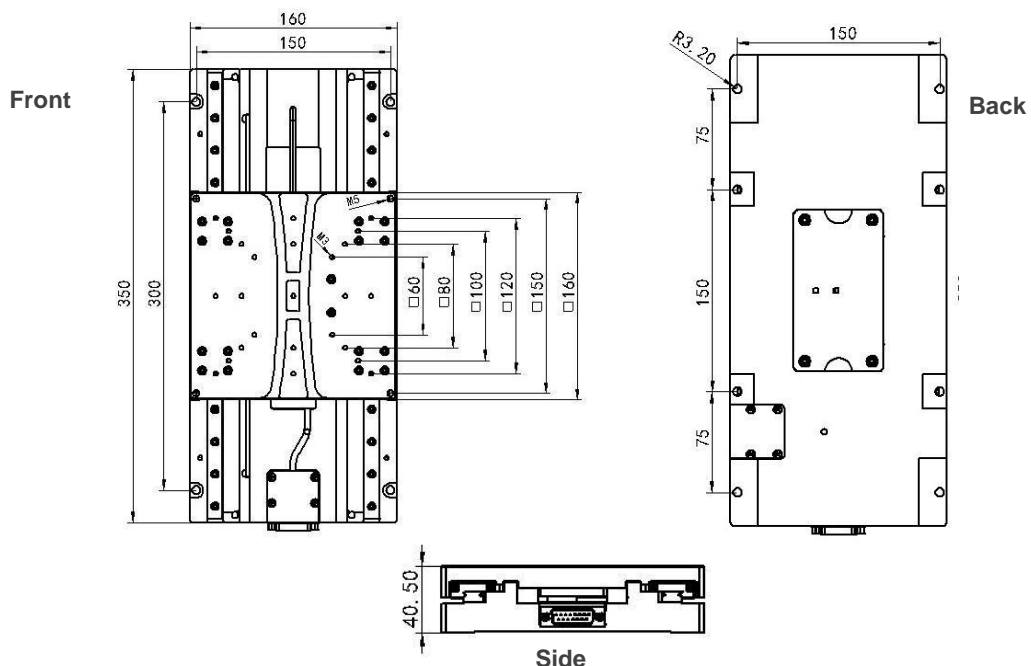

Linear Piezo Stage - ST-LS6-200

Our ST-LS6-200 is a linear piezo stage with stroke up to 200mm. It has a maximum load capacity of 20kg and has repeatability of +/-200mm.

Feature

- Piezoelectric motor drive, self-locking when power off, saving energy and reducing heat generation
- Simple and compact design
- Grating feedback, optional resolution
- Can be used in optical assembly, micro-nano processing, laser, automation and other fields



Specification

Model	ST-LS6-200
Stroke(mm)	200
Driver	Piezoelectric Motor(316)
Maximum Load Capacity(KG)	20
Maximum Speed(mm/s)	50
Minimum Step Size(nm)	100
Repeatability(nm)	+/-200
Position Sensor	Grating
Material	Aluminum Alloy
Weight(KG)	5

Drawings

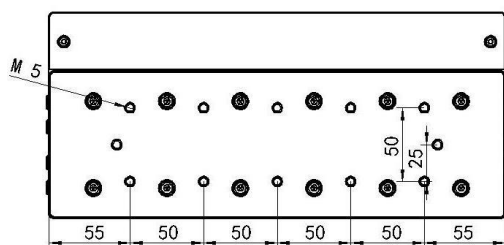

Front

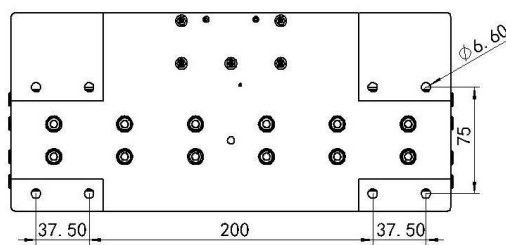

Back

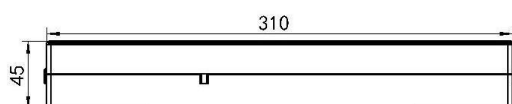

Side

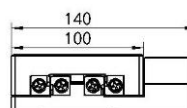

Side