



Microscope USB3.0 CMOS Eyepiece Camera

MCMOS-EP Series



2022 V1

For customized projects please Contact us:

info@simtrum.com

Microscope USB3.0 CMOS Eyepiece Camera is an economic version with a simple and compact structure USB3.0 CMOS eyepiece camera. So here, the S means simple and compact. USB3.0 is used as the data transfer interface.

Microscope eyepiece camera with 23.2 diameter and compact size;

The MCMOS-EP series comes with a high-speed USB3.0 interface and high frame rate video display keeping the screen smooth without interruption;

Also, the MCMOS-EP series comes with an advanced video & image processing application.

The MCMOS-EP series can be widely used to transfer the mono or binocular student microscopes to the digital microscope.

With 23.2 to 30mm or 23.2 to 30.75 convert ring, the MCMOS-EP camera can also change the stereo microscope to a digital stereo microscope.



Features

- Microscope eyepiece camera with 23.2 diameter and compact size;
- Easy to extend to C or CS- Mount camera with high-quality lens(optional);
- High-quality camera with Aptina CMOS sensor;
- Auto white balance and auto-exposure; Brightness, contrast, chroma, and saturation can be adjusted;
- A high-speed USB3.0 interface and high frame rate video display keep the screen smooth without interruption;
- With advanced video & image processing application;
- Providing Windows/Linux/Mac OS multiple platforms SDK;
- Native C/C++, C#/VB.NET, DirectShow, Twain Control API;

Specifications

Order Code	Sensor & Size	Pixel(μm)	G Responsivity Dynamic range SNRmax	FPS/Resolution	Binning	Exposure
MCMOS-EP05100KPA TP305100A(New) 06/05/2020	5.1M/IMX335(C) 1/2.8" (5.18x3.89)	2.0x2.0	505mV 70dB 43dB	20@2592x1944 20@1280x960 20@640x480	1x1 1x1 1x1	0.1-2000 ms
MCMOS-EP05000KPA TP305000A	5.0M/MT9P001(C) 1/2.5"(5.70x4.28)	2.2x2.2	0.53 V/lux-sec 66.5dB 40.5dB	15@2560x1920 15@2048x1536 30@1920x1080	1x1 2x2	Auto
MCMOS-EP05000KPC TP305000C	5.0M/SC5033(C) 1/2.7"(5.18x3.89)	2.0x2.0	2 V/lux-sec 64dB 35dB	15@2592x1944 20@2048x1536 20@1600x1200 30@800x600	1x1 2x2	Auto

* C: Color; M: Monochrome; Default shutter: Rolling Shutter

Other Specification for MCMOS-EP Series	
Spectral Range	380-650nm (with IR-cut Filter)
White Balance	Auto White Balance
Color Technique	N/A
Capture/Control SDK	Windows/Linux/macOS/Android Multiple Platform SDK(Native C/C++, C#/VB.NET, Python, Java, DirectShow, Twain, etc)
Recording System	Still Picture and Movie
Cooling System*	Natural
Operating Environment	
Operating Temperature (in Centidegree)	-10~ 50
Storage Temperature (in Centidegree)	-20~ 60
Operating Humidity	30~80%RH
Storage Humidity	10~60%RH
Power Supply	DC 5V over PC USB Port
Software Environment	
Operating System	Microsoft® Windows® XP / Vista / 7 / 8 /10 /11 (32 & 64 bit) OSx(Mac OS X) Linux
PC Requirements	CPU: Equal to Intel Core2 2.8GHz or Higher
	Memory: 2GB or More
	USB Port: USB3.0 High-speed Port
	Display: 17" or Larger CD-ROM

Dimension

The MCMOS-EP series body, made from aluminum alloy blackening, ocular housing: Dia.32 X 56mm ensures a heavy-duty, workhorse solution. The camera is designed with a high-quality IR-CUT filter to filter the infrared light and protect the camera sensor. No moving parts included. This design ensures a rugged, robust solution with an increased lifespan when compared to other industrial camera solutions.

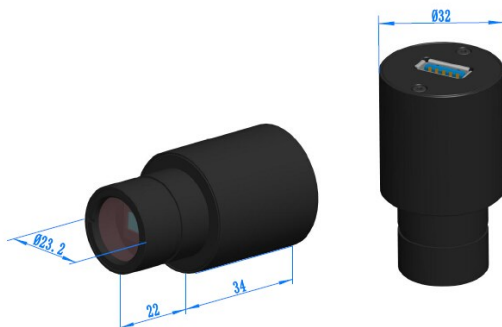

Packing Information



Standard Package	
A	Carton L:50cm W:30cm H:30cm (20pcs, 12~17Kg/ carton), not shown in the photo
B	Gift box L:15cm W:15cm H:10cm (0.25~0.35Kg/ box)
C	One MCMOS-EP series camera
D	High-Speed USB3.0 USB315-ATA USB 3.0 A Male to A Male Cable,1.5m
E	CD (Driver & utilities software, Ø8cm)
Optional Accessory	
F	C-Mount adapter housing:108027(HS502)
G	108015(Dia.23.2mm to 30.0mm ring)/Adapter rings for 30mm eyepiece tube
H	108016(Dia.23.2mm to 30.5mm ring)/Adapter rings for 30.5mm eyepiece tube
I	108016(Dia.23.2mm to 30.5mm ring)/Adapter rings for 30.5mm eyepiece tube
J	Calibration kit
	106011/TS-M1 (X=0.01mm/100Div.); 106012/TS-M2(X,Y=0.01mm/100Div.); 106013/TS-M7(X=0.01mm/100Div., 0.10mm/100Div.)